

FEATURES

- Total start-stop feature allows flow to activate electric motor
- Built-in unloader
- "HR" anti-corrosion surface treatment on the manifold
- New generation seal package
- New dust protection chamber
- Solid ceramic plungers
- New oversized plunger guide
- New optimized inlet and outlet valves
- New oil seal
- Left side shaft, right side manifold

**SPECIFICATIONS**

Pump Model	ET1504E34UTSL	ET1505E34UTSL	ET1506E34UTSL
Maximum Volume	2.0 GPM	2.1 GPM	2.9 GPM
Maximum Discharge Pressure	2,610 PSI		
Horsepower	3.6 EBHP	3.8 EBHP	5.2 EBHP
Maximum Pump Speed	3400 RPM		
Maximum Inlet Pressure	125 PSI		
Max. Inlet Vacuum	Flooded		
Plunger Bore (in / mm)	.591 in./15 mm		
Plunger Stroke (in / mm)	.157 in./4 mm	.197 in./5 mm	.236 in.6 mm
Oil Capacity	8.5 oz.		
Maximum Fluid Temperature	165° F		
Inlet Port Thread	1/2"-10 BSP-F		
Discharge Port Thread	3/8"-13 BSP-F		
Shaft Diameter	5/8 in		
Shaft Orientation	Left-hand		
Unloader Orientation	Right-hand		
Weight	11.0 lbs.		
Dimensions - Nominal	8" x 7.4" x 4.7"		



Instructions and Recommendations for the Installation of *ET Series Pumps*

Maximum temperature of the water through the pump is 165°F (73°C).

In order to obtain maximum performance in terms of duration of seals and valves, it is necessary to respect a few simple rules, as follows:

1) **In order to avoid damage caused by cavitation, the pump must be pressure fed.**

The higher the inlet pressure, the longer the life of the wet end of the pump.

When working at 165°F (73°C), the minimum feed pressure - measured directly in the inlet port of the pump when it is working - is 45 psi (3 bar).

The minimum feed pressure according to the different temperatures are:

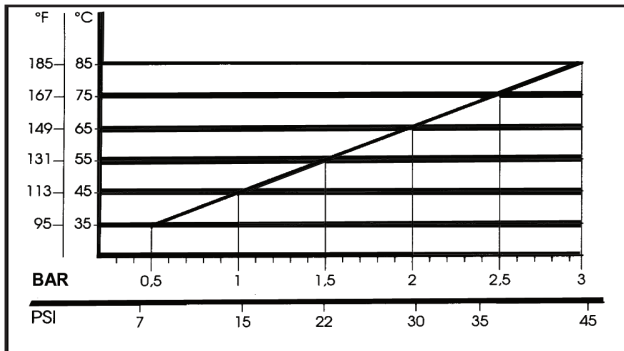

Naturally, if the application allows for feeding the pump with 45 psi (3 bar) even at low temperatures (for example: 115°F/45°C the life of the wet end of the pump will be even longer).

2) **The plumbing which feeds the pump must be of a diameter at least equal to the inlet port.**

Also, follow the suggestions below:

a) Make the plumbing as short and straight as possible, preferably in an upward direction to facilitate the expulsion of eventual air bubbles naturally if compatible with the requirements of the system.

b) It is always useful to put a filter at the inlet with capacity of 4 to 5 times the flow of

the pump, for example for a 4 gpm (15 l/min) pump, put a filter from 16 to 20 gpm (60-75 l/min). The mesh size suitable for this application is 0.016" (.4 mm).

c) It is extremely important to put a pressure switch on the suction port of the pump, and in any case downstream from the filter, so that it can stop the pump should the feed pressure drop by 20% due to the filter clogging or failure of the feed pump, etc.

3) **Change of oil**

We recommend the **first oil change after the first 50 hours**, with the **pump stopped** and the **oil still warm**.

This change is not recommended because the oil has lost its properties, but rather to eliminate the impurities that have gotten into the oil during the running-in phase. If these impurities are not removed, but are allowed to remain in the oil, they *may cause premature wear* to the moving parts and the oil seals. **After this initial change, the oil can then be changed every three months or 300 hours of operation thereafter.**



Please note: If the pump works in conditions with high humidity and with sharp temperature changes, it is possible that condensation will appear inside the crankcase, which mixing with the oil can change its properties. This is easy to see because the oil changes to a white, milky color.

If the pump does not have excessive water leaking from the packings, and the oil becomes milky, the oil has to be changed more frequently. The percentage of water in the oil must not exceed 20%.

Use oil per the following chart:

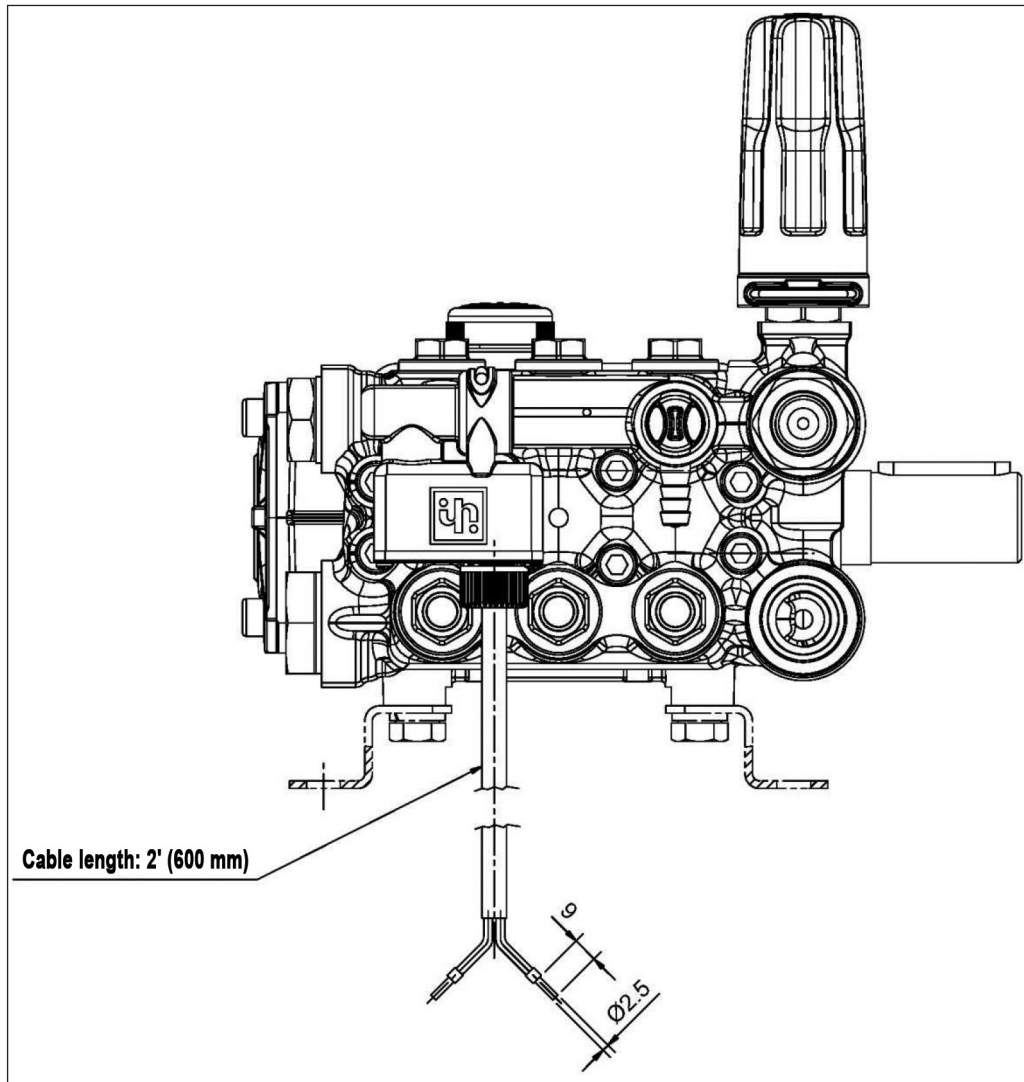
CHART OF COMPATIBLE OILS SAE15W40	
General Pump	Series 100
BP	VISCO 2000
CASTROL	CWX
MOBIL	SUPER
SHELL	HELIX SUPER
TOTAL	QUARTZ 4000-5000

OPERATIONAL SPECIFICATIONS

Maximum Voltage	250 V ~
Maximum Load	16 (4) A
Protection Grade	IP55
	Gun Closed
	Gun Open

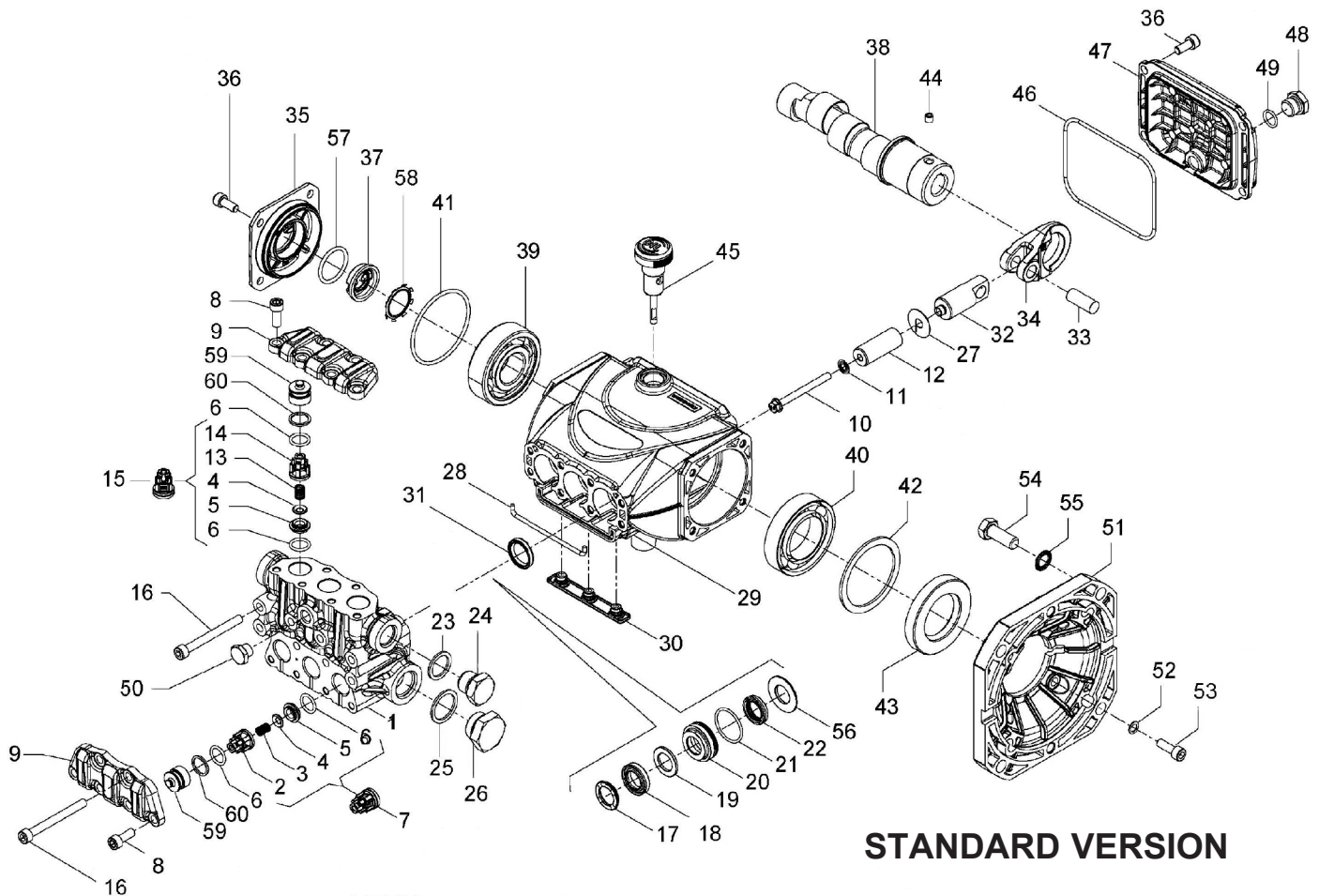

STANDARD VERSION

PARTS LIST

ITEM	PART NO.	DESCRIPTION	QTY	ITEM	PART NO.	DESCRIPTION	QTY	ITEM	PART NO.	DESCRIPTION	QTY
1.	53122115	Manifold, Ø 15	1	23.	96738000	Washer, Ø17.5x23x1.5	1	40.	91846400	Bearing	1
2.	36211951	Inlet Valve Guide	3	24.	98210050	Plug, 3/8"x13	1	41.	90389800	O-ring, Ø56.82x2.62	1
3.	94732600	Spring, Ø 6x12	3	25.	96751400	Washer, Ø 21.5x27x1.5	1	42.	60210189	Spacer	1
4.	36211272	Valve, Spherical	6	26.	98218700	Plug, 1/2"x10	1	43.	90167500	Stop Ring Ø35x62x10	1
5.	36211366	Valve Seat	6	27.	96699000	Gasket, Ø 7.5x23x0.5	3	44.	99179000	Screw M6x06	1
6.	90367400	O-ring, Ø12x2	6	28.	53210382	Gasket, Ø3x85	1	45.	98210800	Oil Dipstick G 3/8"x45	1
7.	36722401	Valve Assembly	3	29.	53010022	Crankcase	1	46.	90391700	O-ring, Ø88.57x2.62	1
8.	99185400	Screw, M6x16	10	30.	58210451	Drip Cover	1	47.	53160022	Rear Cover	1
9.	53211815	Valve Cover	2	31.	90159300	Oil Seal, Ø 18x24x4	3	48.	98204250	Plug, 3/8"x9	1
10.	99169000	Plunger Bolt, M5x55	3	32.	53050066	Piston Guide	3	49.	701013	O-ring, Ø 10.82x1.78	1
11.	96690500	Washer, Ø 5x11.5x0.4	3	33.	97733800	Piston Pin, Ø 10x26.5	3	50.	98196800	Plug, 1/8"x8	1
12.	53040009	Plunger, Ø 15x38.5	3	34.	53030022	Connecting Rod	3	51.	10034422	Flange for Electric Motor	1
13.	94733300	Spring, Ø 6.2x10.4	3	35.	53150022	Side Cover Housing	1	52.	96693800	Washer Ø6.4x10x0.7	4
14.	36211151	Outlet Valve Cage Guide	3	36.	99183700	Screw M6x14	8	53.	99186700	Screw M6x18	4
15.	36719301	Complete Outlet Valve	3	37.	53210851	Oil Level Indicator	8	54.	99334500	Screw 3/8"x16	4
16.	99199000	Screw, M6x60	8	38.	60022465	Crankshaft, Ø 5.0 (ET1505E34UTSL)	1	55.	96710400	Washer Ø 10.5x16x1	4
17.	63101051	Head Ring, Ø 15	3		60022265	Crankshaft, Ø 4.0 (ET1504E34UTSL)	1	56.	53210670	Support Ring, Ø 15	3
18.	90261100	Packing, Ø15x24x5.4/3.4HP	3		60022965	Crankshaft, Ø6.5 (ET1506E17UTSL)	1	57.	90385900	O-ring Ø 25.07x2.62	1
19.	90508990	Anti-ext. Ring, Ø15x24x2	3	39.	91832800	Bearing	1	58.	90067100	Stop Ring	1
20.	53210170	Support Ring, Ø 15	3					59.	53211970	Inlet/Outlet Valve Cap	6
21.	90360400	O-ring, Ø25.12x1.78	3					60.	90509300	Stop Ring, Ø 16.4x13.2x1.3	6
22.	90260800	Packing, Ø15x22x5, LP	3								

START-STOP MANIFOLD

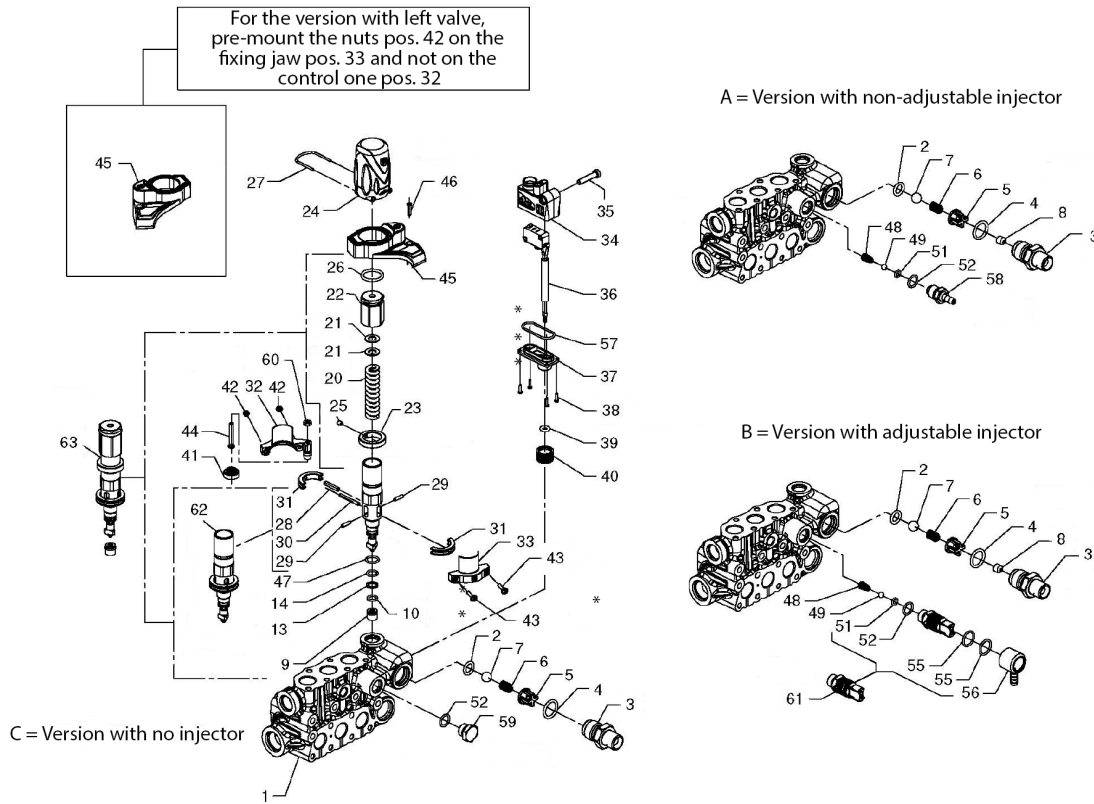

* When assembling apply petroleum based grease

PARTS LIST

ITEM	PART NO.	DESCRIPTION	QTY	ITEM	PART NO.	DESCRIPTION	QTY	ITEM	PART NO.	DESCRIPTION	QTY
1.	53122715	Manifold, Ø 15	1	24.	36356051	Regulating Knob	1	43.	99072930	Screw, M3x14	2
2.	90382300	O-ring Ø 9.92x2.62	1	25.	99126700	Screw, M4x5	1	44.	36357465	Adjustment Screw	1
3.	36347970	Nipple, 3/8" BSP-M	1	26.	90384500	O-ring, Ø 18.72x2.62	1	45.	36358/51	Cover	1
	36348770	Nipple, 3/8" NPT-M (opt)	1	27.	10084666	Clip, Regulating Knob	1	46.	99072900	Screw, Ø 3x14	1
	36348870	Nipple, M22x1.5-M (opt)	1	28.	97613800	Cylindrical Pin, 4.0m6x20.0	1	47.	90358700	O-ring, Ø 11.11x1.78	1
	36348870	Nipple, 3/8" BSP-F (opt)	1	29.	97613500	Cylindrical Pin, 3.0m6x12.0	2	48.	94821700	Conical Spring, Ø 4.3x7.1x11	1
	36349070	Nipple, 3/8" NPT-F (opt)	1	30.	97613700	Cylindrical Pin, 3.0m6x28.	1	49.	97478200	Ball, 7/32"	1
4.	90383900	O-ring, Ø 15.88x2.62	1	31.	36356651	Semi-Disc	2	51.	90357300	O-ring, Ø 5.28x1.78	1
5.	36310451	Guide Valve	1	32.	36356351	Clamping Jaw	1	52.	90358500	O-ring, Ø 10.82x1.78	1
6.	94735500	Spring, Ø 8.5x12	1	33.	36356251	Clamping Jaw	1	55.	90359100	O-ring, Ø 14.00x1.78	1
7.	97483800	Ball, Ø 13/32"	1	34.	36355951	Start/Stop Housing	1	56.	36023551	Adjustment Hose Connector	1
8.	10079566	Nozzle, Ø 2.0	1	35.	99159400	Screw, M5x25	1	57.	90360800	O-ring, 28.30x1.78	1
9.	36348366	Valve Seat	1	36.	10745901	Switch Wiring	1	58.	36349270	Hose Barb	1
10.	90357800	O-ring, Ø 7.66x1.78	1	37.	36355451	Lid, Start/Stop Housing	1	59.	98204100	Plug, G1/4"x9	1
14.	90358100	O-ring, Ø 8.73x1.78	1	38.	99034400	Screw, Ø 2.2x9.5	4	60.	92192400	Nut, M4x3.2	1
20.	94739900	Spring, Ø 11.3x59.0	1	39.	90381400	O-ring, Ø 5.23x2.62	1	61.	36606201	Chem Injector, Complete	1
21.	36348651	Sliding Washer	2	40.	92974100	Wire Retaining Collar	1	62.	36607301	Shutter Guide	1
22.	36355370	Pressure Regulator	1	41.	36358847	Bellows	1	63.	36607501	Complete Valve	1
23.	36347770	Max Pressure Ring	1	42.	92193000	Nut, M3x2.4	2				

REPAIR KITS

TORQUE SPECS*

STANDARD

KIT NO.	K309	K311	Ø 15		
			K312	K312H Hot Kit	K313
ITEM NO'S INCLUDED IN KIT	2, 3, 4, 5, 6, 13, 14, (7), (15)	31	17, 18, 19, 21, 22	17, 18, 19, 21, 22	17, 18, 19, 20, 21, 22, 56
NUMBER OF PIECES	6	3	3		1

START-STOP

KIT NO.	K280	K348	K406
ITEM NO'S INCLUDED IN KIT	48, 49, 51, 52, 58	48, 49, 56, 61	2, 4, 5, 6, 7, 32, 33, 41, 42, 43, 44, 60, 63
NUMBER OF PIECES	1	1	1

STANDARD

Position	Ft.-Lbs.	Nm.
8	8.9	12
10	4.4	6
16	8.9	12
24**	30	40
26	30	40
36	7.4	10
48	14.8	20
50**	9.6	13
53	7.3	10

START-STOP

Position	Ft.-Lbs.	Nm.
3	10.33	44
8	8.85	12
25	0.44	0.6
35	2.21	3
38	0.15	0.2
43	0.59	0.8
46	0.59	0.8
58	14.8	20
59	14.8	20
60	2.21	3
61	11.06	15
62	10.33	14
63	10.33	14

**Use Loctite 542 Red

*Decrease torque by 20% if threads are lubricated.

DIMENSIONS

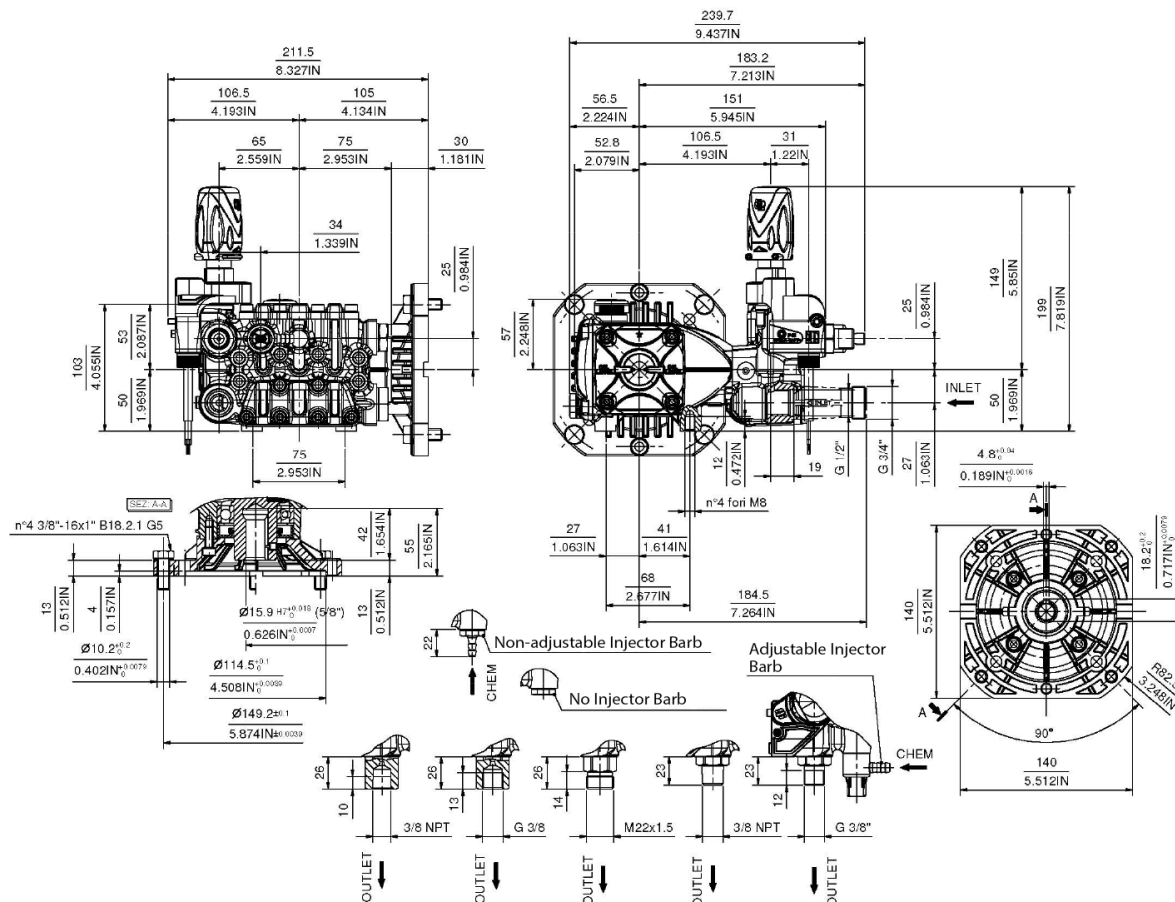

WARNING: High Pressure Systems require a primary pressure regulating device (i.e. regulator, unloader) and a secondary pressure relief device (i.e. pop-off valve, relief valve). Failure to install such relief devices properly could result in personal injury or damage to pump or property. GP does not assume any liability or responsibility for the operation of the user's high pressure system.

